

Ogura® ELECTRO-HYDRAULIC REBAR CUTTER

Model: HBC-313, 613, 316,
816, 16R, 19R, 520,
22, 225, 232

Instruction Manual

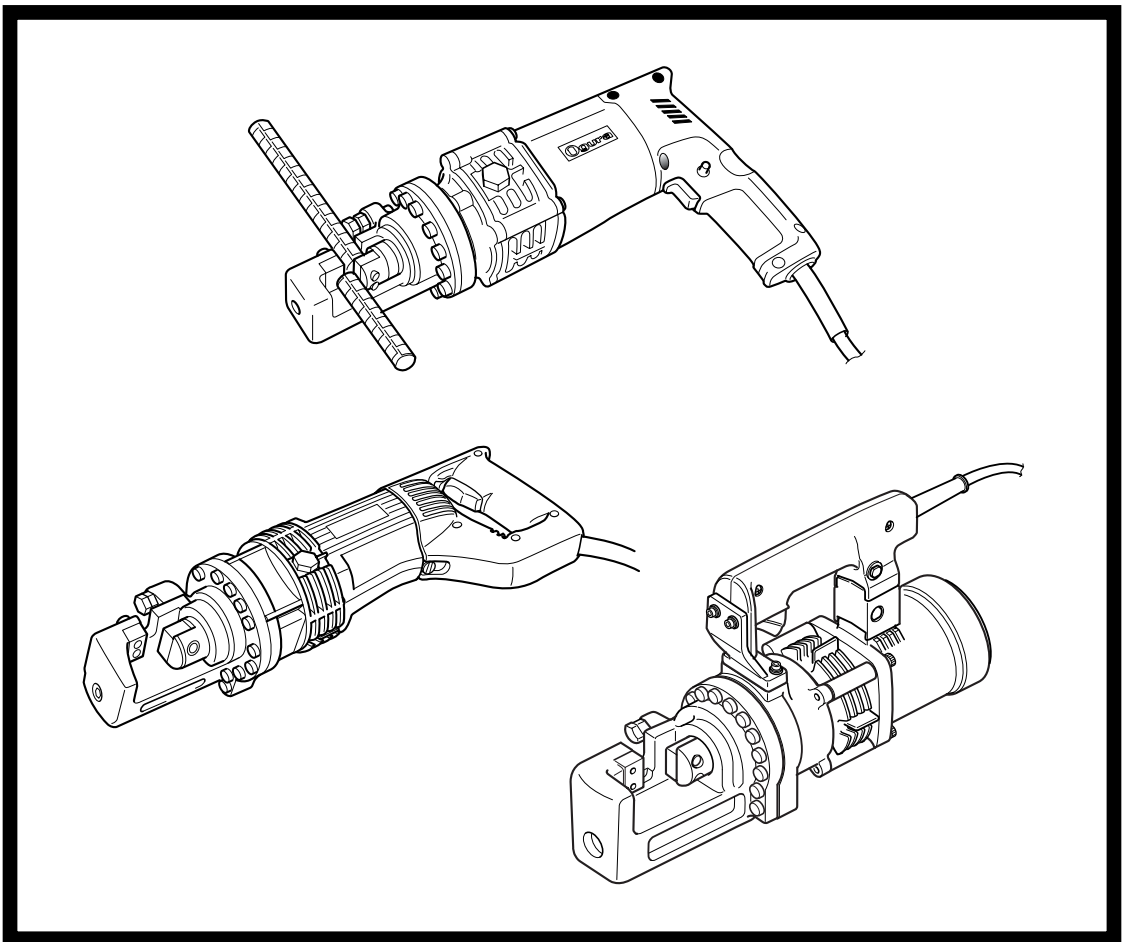

Before installing and operating this machine, read, understand and follow all instructions and operating procedures. Keep these instructions with the machine.

TABLE OF CONTENTS

IMPORTANT SAFETY INSTRUCTIONS	3
PARTS NAMES	6
SPECIFICATIONS	7
OPERATING PROCEDURE	9
BLADES REPLACEMENT PROCEDURE	12
CARBON BRUSHES REPLACEMENT PROCEDURE	13
ADDING OIL	14
TROUBLE SHOOTING	15

Meaning of "caution" and "warning" indications

Caution: Indicates a potentially hazardous situation which, if not avoided, may result in minor or moderate injury. This is also used to alert against unsafe practices associated with events that could lead to personal injury.

Warning: Indicates a potentially hazardous situation which, if not avoided, will result in death or serious injury.

***** Ogura & Co., Ltd. shall not be responsible for any incidental damages or personal injuries resulting from negligence of Warnings and Safety Instructions contained in the Instruction Manual.**

⚠ WARNING



Read, understand and follow all safety instructions and operating procedures. If you do not understand the instructions, or if conditions are not correct for proper operation, **DO NOT OPERATE THE MACHINE**. Consult your supervisor or other responsible person.

⚠ WARNING LABELS RELATED SAFETY



Flying debris and loud noise hazards. Wear ear and eye protection.



Hazardous voltage. Disconnect all power before working on this equipment. Failure to observe this instruction will result in death or serious injury.



Moving blade. Keep hands clear while machine is operating. Turn power off before servicing.

GENERAL POWER TOOL SAFETY WARNINGS

1. Before Operating Tool Read Instruction Manual.

2. Keep Work Area Clean

- Cluttered areas and benches invite injuries.

3. Consider Work Area Environment

- Do not expose tool to rain.
- Do not use tool in damp or wet locations.
- Keep work area well lit.
- Do not use tool in presence of flammable liquids or gases.

4. Guard Against Electric Shock

- Prevent body contact with grounded surfaces, e.g. pipes, ranges, refrigerator enclosures, etc.

5. Keep Children Away

- Do not allow children or unauthorised personnel to handle tool or extension cord. All visitors should be kept away from work area.

6. Store Idle Tools

- When not in use, tools should be stored in a dry and secure place - out of reach of children.

7. Do Not Force Tool

- It will do the job better and safer at the rate for which it was intended.
- Do not force tool to work beyond its ability. Excessive load will cause seizure of the motor, overheating, smoke and fire.

8. Use Right Tool

- Do not force small tool or attachment to do the job of a heavy-duty tool.
- Do not use tool for purpose not intended.

9. Dress Properly

- Do not wear loose clothing or jewellery as they can be caught in moving parts.
- Rubber gloves and non-skid footwear are recommended when working outdoors.
- Wear protective hair covering to contain long hair.

10. Always Wear Safety Glasses or Goggles

11. Do Not Abuse Power Cord

- Never carry tool by its power cord or pull on the cord to disconnect it.
- Keep cord away from heat, oil and sharp edges.

12. Secure Work

- Use clamps or a vice to hold the work. This frees both hands to properly hold, control, and operate the tool. Failure to properly secure the work may result in injury.

13. Do Not Overreach

- Keep proper footing and balance at all times.

14. Maintain Tools Carefully

- Keep tools sharp and clean for better and safer performance.
- Follow instructions for lubricating and changing accessories.
- Inspect tool power cord periodically and, if damaged, have repaired by authorized service facility.
- Keep handles dry, clean, and free from oil and grease.

15. Disconnect Tools From Power Source

- When not in use, before servicing, and when changing accessories, such as blades and cutters.

16. Remove Keys and Wrenches

- Form habit of checking to see that keys and wrenches are removed from tool before starting operation.

17. Avoid Unexpected Operation

- Do not carry plugged in tool with finger on switch.
- Be sure switch is off before plugging in.

18. Use Outdoor Extension Cord For Outside

- When tool is used outdoors, use only extension cord intended for use outdoors and so marked.

19. Stay Alert

When using electric tools,

- Read and follow operating procedures in this instruction manual.
- Consider safety of others.
- Operate tool with care.
- Watch what you are doing.
- Use common sense.
- Do not operate tool when you are tired.

GENERAL POWER TOOL SAFETY WARNINGS

20. Check For Damaged Parts

- Before using the tool, carefully check all parts for damage, including guards, to ensure that they will operate correctly and perform their intended function.
- Check for any misalignment or binding of moving parts; damaged or broken parts and mountings; and any other conditions that may affect its operation.
- Do not use tool if electric plug or cord is damaged. Do not use tool if it was dropped or damaged in any way.
- A guard or other part that is damaged should be properly repaired or replaced by an authorized service centre unless otherwise indicated in this manual.
- Do not use tool if switch does not turn it on and off. Have damaged or defective switch replaced by an authorized service centre.

21. Only Use Specified Accessories and Attachments.

- Use only the accessories and attachments described in this manual and the Ogura catalogue. Use of other accessories or attachments may result in an accident or injury.

22. Service at Factory Authorized Repair Centre Only

- Service this electric appliance in accordance with the relevant safety regulations.
- Repairs to electric appliances should only be done by a qualified person. Repairs by others may endanger the user.
- Contact your dealer to arrange servicing.

23. To throw a way the waste in illegal manner is strictly prohibited. Follow the local regulations.

ELECTRO-HYDRAULIC REBAR CUTTER SAFETY WARNINGS

- Cut pieces may fly off during cutting. Confirm the safety of surroundings before cutting.
- Keep fingers and face away from the cutting area. Cut pieces may fly off and cause injury to the operator.
- Material is ejected at end of cut. Be sure that ejected slug cannot fall and cause injury. Consider the safety of others when cutting.
- Never cut rebar when the piece to be cut off is less than 200 mm in length. Smaller pieces have a tendency to fly off and may cause injury to the operator and the surroundings.
- Replace any broken, worn, deformed, cracked or damaged parts immediately with Ogura identical replacement parts. Damaged or broken parts may cause further damage to the tool as well as serious injury to personnel.
- Tool should be connected only to a power supply of the same voltage as indicated on the product label, and can only be operated on single-phase AC supply.
- If extension cord is used, the wire size should be equal to or greater than that specified below. (Use only 3-wire extension cord that has a 3-pin earthed plug, and 3-pin earthed socket that matches the plug on the tool.) Replace or repair a damaged cord.
- Always adjust the Hold Bolt to the diameter of the rebar and retighten Hold Nut before cutting.
- Confirm the Hold Nut is tightened properly before cutting starts.

CAUTION

Avoid Electric Shock

- Power source with a breaker is recommended to avoid the electric shock,

Follow Local Noise Level Regulations

- Operate tools within a soundproofed enclosure if necessary.

Check Before Operation

- The tool is manufactured for the purpose of cutting reinforcing bars. Do not use the tool for a purpose it was not intended for. Only use Ogura genuine blades. Replace parts when and as directed in this instruction manual.
- Confirm that all bolts and screws are tightened properly before operation begins.

Operate Tool With Proper Voltage

- The tool should be connected only to a power supply of the same voltage as indicated on the product label. If connected to a higher voltage the motor will over speed and eventually burn out. If connected to a lower voltage the motor will be damaged and eventually break up.

Pay Attention When Operating

- Keep proper footing and balance at all times.
- Stop operation immediately when the tool is out of order or makes abnormal sound during use.
- During tool operation, keep hands and face away from the blades, all moving parts and the scrap ejection section.
- Carbon brushes should be replaced every 200 hours or when the length of the brush is reduced to 6 mm.

Protect Tool

- Handle tool carefully. If it is dropped or struck it could be damaged.
- The motor air vents should be open and unobstructed as they provide cooling for the motor. Keep the air vents clear of dust, dirt and debris or the motor will over heat and be damaged.

Maintain Tool

- Keep tool clean to stay in best condition. Always wipe off dirt and oil from the motor, switch, and handles.
- Use only Ogura genuine parts for replacement.
- Check the tool regularly so that it can be used safely and effectively.
- Stop operation immediately and contact your dealer if the tool is making abnormal sounds or is out of order in any way. Do not disassemble the tool as the internal components are sensitive to damage from dust, dirt, contamination of the hydraulic fluid or improper handling.
- This is a hydraulic tool powered by electricity. When the temperature is low, the oil will thicken and tool may not work properly. Idle tool for a few minutes before use.

Ear protection

- Typical A-weighted sound pressure level: 96 dB(A)
Typical A-weighted sound power level: 75 dB(A)

CAUTION -Wear ear protection.-

The typical weighted root mean square acceleration Value is not more than 2.5m/S²

Contact your dealer for service and check-up.

PARTS NAMES

HBC-313, 316, 16R

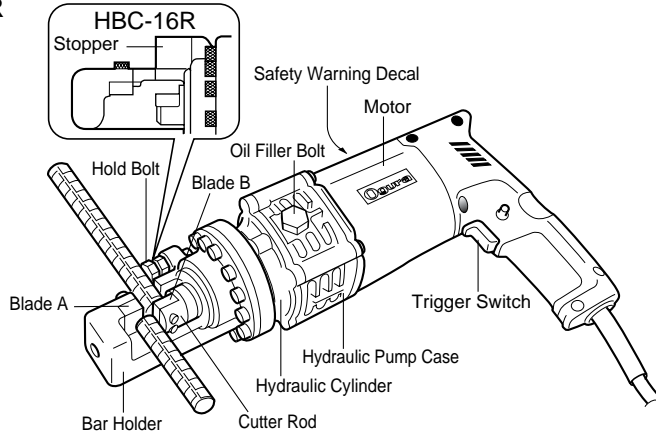

HBC-613, 816

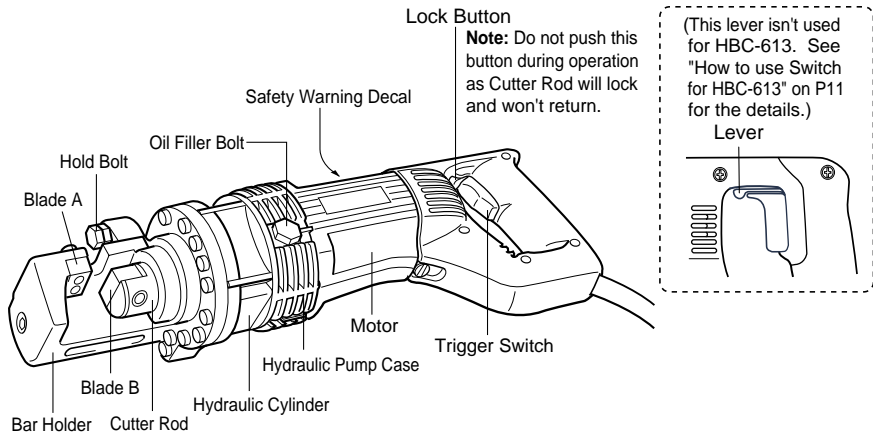

HBC-520, 19R, 22, 225, 232

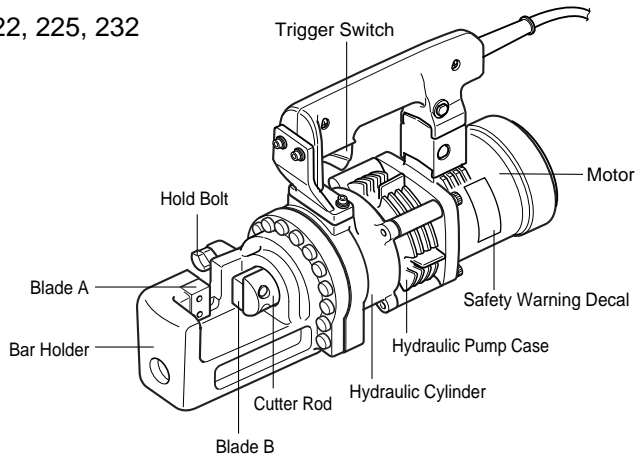

SPECIFICATIONS

■ Specifications

Model	HBC-313		HBC-613		HBC-316	
115 V / 230 V a.c 50 / 60 Hz Single-Phase	580 W □		710 W □		580 W □	
Weight	5.4 Kg		7.3 Kg		5.8 Kg	
Dimensions (L X W X H)	362 X 205 X 106.5 mm		447 X 151 X 110 mm		378 X 205 X 108 mm	
Cutting Capacity	Tensile Strength	Max. Dia.	Tensile Strength	Max. Dia.	Tensile Strength	Max. Dia.
	490 N / mm ² (50 kg / mm ²) (71,000 P.S.I.)	13 mm (#4)	490 N / mm ² (50 kg / mm ²) (71,000 P.S.I.)	13 mm (#4)	490 N / mm ² (50 kg / mm ²) (71,000 P.S.I.)	16 mm (#5)
	620 N / mm ² (63 kg / mm ²) (90,000 P.S.I.)	10 mm (#3)	620 N / mm ² (63 kg / mm ²) (90,000 P.S.I.)	10 mm (#3)	620 N / mm ² (63 kg / mm ²) (90,000 P.S.I.)	13 mm (#4)
Cutting Speed	1.5 seconds		1.5 seconds		2.0 seconds	
Standard Accessories	Carrying case					
	Hydraulic oil #46					
	Hex wrenches (3, 4, 5 mm)					
	Double open end wrenches (14•17 mm)					

Model	HBC-816		HBC-16R		HBC-19R	
115 V / 230 V a.c 50 / 60 Hz Single-Phase	1,010 W □		580 W □		700 W	
Weight	8.8 Kg		6.2 Kg		11.4 Kg	
Dimensions (L X W X H)	492 X 165 X 120 mm		410 X 205 X 180 mm		401 X 126 X 226 mm	
Cutting Capacity	Tensile Strength	Max. Dia.	Tensile Strength	Max. Dia.	Tensile Strength	Max. Dia.
	620 N / mm ² (63 kg / mm ²) (90,000 P.S.I.)	16 mm (#5)	440 N / mm ² (45 kg / mm ²) (63,000 P.S.I.)	16 mm (#5)	620 N / mm ² (63 kg / mm ²) (90,000 P.S.I.)	19 mm (#6)
			620 N / mm ² (63 kg / mm ²) (90,000 P.S.I.)	13 mm (#4)		
Cutting Speed	1.5 seconds		2.0 seconds		2.5 seconds	
Standard Accessories	Carrying case					
	Hydraulic oil #46					
	Hex wrenches (3, 4, 5 mm)		Hex wrenches (3, 4, 5, 6 mm)			
	Double open end wrenches (14•17 mm)				Double open end wrenches (17•19 mm)	

Specifications

Model	HBC-520		HBC-22	
115 V / 230 V a.c 50 / 60 Hz Single-Phase	1,330 W □		700 W	
Weight	12.2 Kg		14.2 Kg	
Dimensions (L X W X H)	396 X 112 X 220 mm		414 X 112 X 238 mm	
Cutting Capacity	Tensile Strength	Max. Dia.	Tensile Strength	Max. Dia.
	620 N / mm ² (63 kg / mm ²) (90,000 P.S.I.)	20 mm (#6)	560 N / mm ² (57 kg / mm ²) (81,000 P.S.I.)	22 mm (#7)
	620 N / mm ² (63 kg / mm ²) (90,000 P.S.I.)		620 N / mm ² (63 kg / mm ²) (90,000 P.S.I.)	19 mm (#6)
Cutting Speed	2.5 seconds		3.0 seconds	
Standard Accessories	Carrying case			
	Hydraulic oil #46			
	Hex wrenches (3, 4, 5, 6 mm)			
	Double open end wernches (17•19 mm)		Double open end wernches (17•22 mm)	

Model	HBC-225		HBC-232	
115 V / 230 V a.c 50 / 60 Hz Single-Phase	1,430 W		1,430 W	
Weight	22.0 Kg		37.6 Kg	
Dimensions (L X W X H)	480 X 138 X 269 mm		543 X 167.5 X 289 mm	
Cutting Capacity	Tensile Strength	Max. Dia.	Tensile Strength	Max. Dia.
	620 N / mm ² (63 kg / mm ²) (90,000 P.S.I.)	25 mm (#8)	620 N / mm ² (63 kg / mm ²) (90,000 P.S.I.)	32 mm (#10)
Cutting Speed	4.0 seconds		7.0 seconds	
Standard Accessories	Carrying case			
	Hydraulic oil #32			
	Hex wrenches (4, 5, 6, 8 mm)		Hex wrenches (4, 5, 6, 8, 10 mm)	
	Double open end wernches (14•17•24 mm)		Double open end wernches (17•30 mm)	

OPERATING PROCEDURE

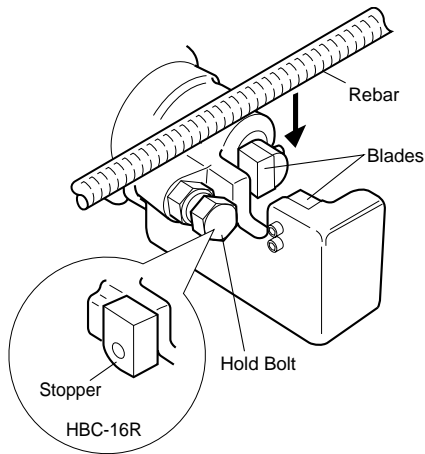

This tool is electro-hydraulic rebar cutter to be designed to cut reinforcing bars.

Read, understand and follow all safety instructions and operating procedures. If you do not understand the instructions or if conditions are not correct for proper operations, do not operate this tool. Consult your supervisor or other responsible person.

⚠ WARNING

1. Before operation, confirm that the position of the operator, relative to the tool, and the surrounding area is safe for operation. Put on safety glasses and wear protective clothing.
2. Refer to the tool specifications in this manual and do not cut rebar of size or hardness that exceeds the cutting capacity of the tool.
3. Do not cut material other than rebar. Please ask the manufacturer if you want to cut other materials.

Cutting Procedure.

1. Position the rebar to be cut so that it is fully between the blades as shown in the figure on the left.

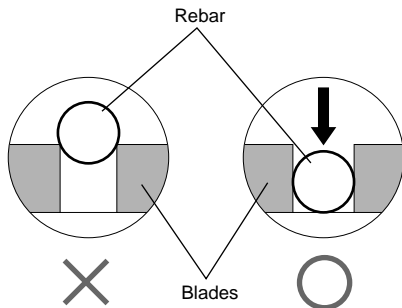

⚠ WARNING

If the rebar to be cut is not positioned fully between the blades, the blades will be damaged; the rebar will be ejected violently and may cause serious personal injury.

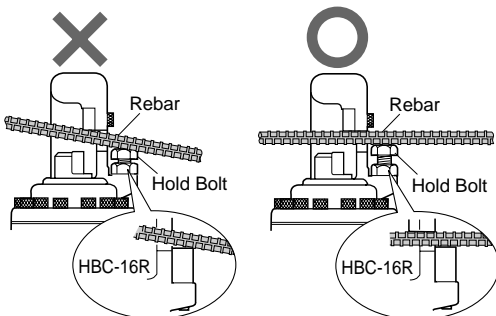

2. Adjust the Hold Bolt according to the diameter of the rebar to be cut so that the rebar is at 90 degrees to the blades as shown in the figure on the left. Tighten the lock nut. The Hold Bolt supports the rebar and keeps it perpendicular to the blades when cutting.

⚠ WARNING

When cutting rebar, adjust the Hold Bolt according to the thickness (diameter) of the rebar to be cut so that the rebar is at 90 degrees to the blades as shown in the figure on the left. Without this adjustment, the cut piece may fly off and cause serious injury to the operator or bystanders.

3. Confirm that the power supply is 115 V / 230 V single phase. Insert the plug into the power outlet and connect the plug to ground (does not apply to HBC-613, 816 and 520) If your power outlet has no earth, first install a ground adapter on the tool side before inserting the plug (excluding HBC-613, 816 and 520)

Operating procedure

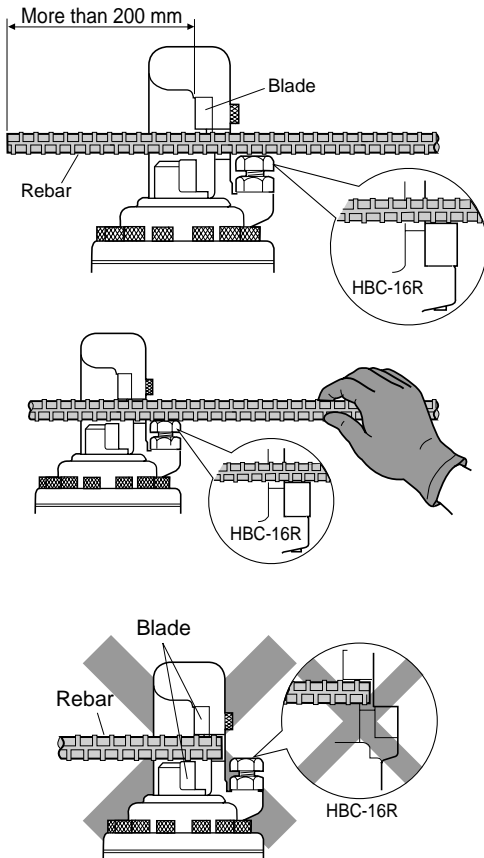

⚠ WARNING

Do not cut rebar when the piece to be cut off is less than 200 mm in length. Cutting shorter length may cause the rebar to fly off during cut and may result in serious personal injury.

⚠ WARNING

Do not cut rebar when it is not properly supported by the Hold Bolt or if the Hold Bolt is not properly adjusted. When cutting, hold the rebar on the Hold Bolt side, as shown in the figure on the left. If not, the cut piece may fly off and cause serious injury to the operator or bystanders.

⚠ WARNING

Replace damaged (chipped, broken, cracked) or deformed blades immediately. The blade will not cut true and may fracture or break causing serious personal injury.

4. Pull the Trigger Switch to start cutting operation. The Cutter Rod will move forward to cut the rebar. Keep the Switch depressed until the Cutter Rod stops at the end of its stroke.
5. Release the switch when the cut is completed and the Cutter Rod has reached the end of its stroke. The Cutter Rod will then return automatically to its starting position. The Cutter Rod will not return if the stroke is not completed. Similarly the Cutter Rod will not be able to move forward again until after it returns completely to its starting position. Pull the switch to start the next cut, only after the Cutter Rod completely returns to its starting position and stops.

Note: If the machine temperature reaches 70deg.C or higher, cutting operation should be stopped to allow the machine to cool down.

⚠ WARNING

When cutting rebar of a high tensile strength the cut piece may fly off and cause serious injury to the operator. Wear safety glasses and confirm that the surrounding area is safe before starting operation.

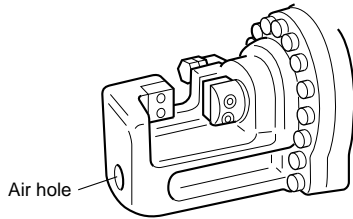

	<p>⚠ WARNING</p> <p>Keep your hands and face away from the blades, the moving parts and the cutting area, during operation. Unplug the machine immediately after use and when the electric supply is cut off.</p>	
--	--	--

Note: Keep the air hole in the end of the Bar Holder clear of dirt and debris. The air hole controls the internal pressure and should not be obstructed.

■ Rotating Function Of Motor (HBC-16R & HBC-19R)

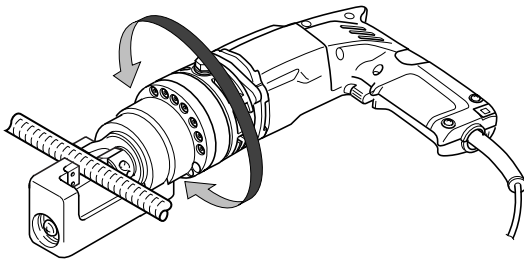

The Motor Body can be rotated through 360 degrees, in either direction, during operation. This feature is particularly useful when working in awkward or narrow areas as it allows the operator to position the tool in the best position for easy operation.

■ Return Valve Operation (HBC-520, 22, 225 and 232)

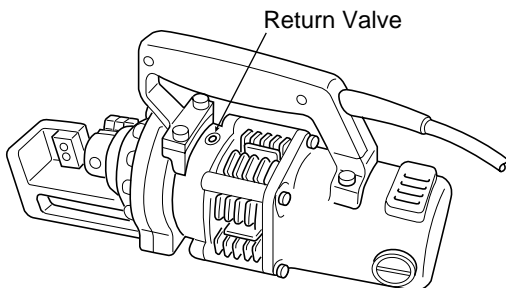

The function of the Return Valve is to allow the Cutter Rod to return to the starting position if it is unable to complete a cut or becomes jammed. Using supplied hex wrench, loosen Return Valve about half a turn in anticlockwise direction. This will release the oil pressure and allow the Cutter Rod to return. Retighten the Return Valve once the Cutter Rod is fully returned and before starting the next operation.

■ Switch Operation (HBC-613)

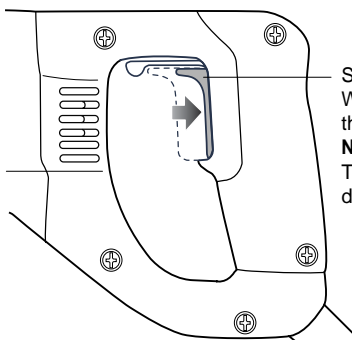

Switch operation for HBC-613
When operating, fully depress the Trigger Switch.
Note: Do not operate with the Trigger Switch only partly depressed.

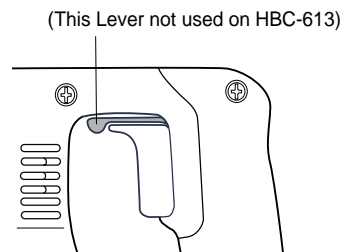

CARBON BRUSHES REPLACEMENT PROCEDURE

When the carbon brushes become less than 6mm the motor force deteriorates because of low rectification. Carbon brushes need to be replaced.

1. Remove the carbon brush cap of the motor outer frame using the standard screwdriver.
2. Replace the carbon brushes with new ones.
3. Put back the caps.

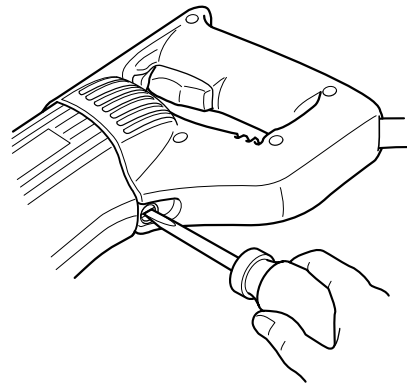
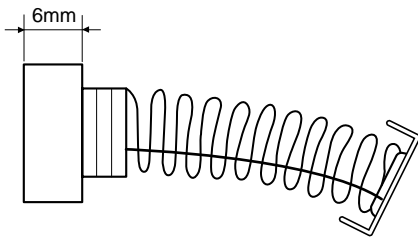

Carbon Brush Size

Model	Part Number	Size
HBC-313 (ø 3 ~ ø 13 mm)	6071060	10 (Width) X 5 (Thickness) X 12 (Length) mm
HBC-613 (ø 3 ~ ø 13 mm)	6402170	11 (Width) X 5 (Thickness) X 17 (Length) mm
HBC-316 (ø 3 ~ ø 16 mm)	6071060	10 (Width) X 5 (Thickness) X 12 (Length) mm
HBC-16R (ø 3 ~ ø 16 mm)	6071060	10 (Width) X 5 (Thickness) X 12 (Length) mm
HBC-816 (ø 3 ~ ø 16 mm)	6400580	11 (Width) X 7 (Thickness) X 17 (Length) mm
HBC-19R (ø 3 ~ ø 19 mm)	6071070	12.5 (Width) X 6.5 (Thickness) X 17 (Length) mm
HBC-520 (ø 3 ~ ø 20 mm)	6415720	13.5 (Width) X 6.5 (Thickness) X 18 (Length) mm
HBC-22 (ø 3 ~ ø 22 mm)	6071070	12.5 (Width) X 6.5 (Thickness) X 17 (Length) mm
HBC-225 (ø 4 ~ ø 25 mm)	6417010	18 (Width) X 7 (Thickness) X 16 (Length) mm
HBC-232 (ø 4 ~ ø 32 mm)	6417010	18 (Width) X 7 (Thickness) X 16 (Length) mm

BLADES REPLACEMENT PROCEDURE

If the cutting edges of the blades are chipped, cracked, deformed, or damaged in any way, their cutting ability will be reduced. Cutting under such conditions may cause further damage and result in personal injury. The blades should be replaced as a set immediately if any damage is found.

⚠ WARNING

When replacing the blades, ensure that the tool is disconnected from the power supply, to prevent accidental operation.

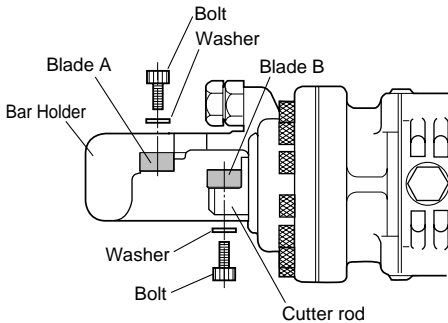

Ensure that Blade A on the Bar Holder and Blade B on the Cutter Rod are fitted in their correct respective positions.

1. Undo the bolts and the washers that hold Blade A and Blade B.
2. Remove dirt and clean the surfaces where the new blades are to be fitted.
3. Fit Blade A to the Bar Holder and Blade B to the Cutter Rod. Replace bolts and washers and tighten firmly. Tighten torque for the bolts of Blades is 10N•m.

⚠ WARNING

The bolts that hold Blade A and Blade B should be tightened regularly. If the bolts become loose the Blades may be damaged and may cause personal injury.

Blade Identification

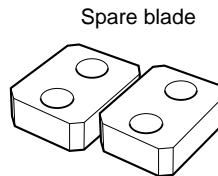
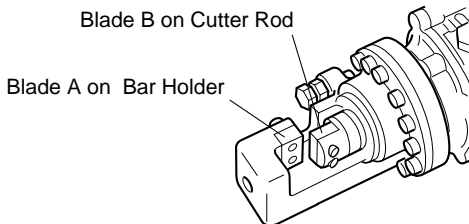

Securing bolts should be firmly tightened. Confirm periodically that the blade is tightened properly.

Blade Size

* Use this table to identify the correct blades for your model.

Model	Part Number (Set)	A (Fitted to Bar Holder)	B (Fitted to Cutter Rod)
HBC-313 (ø 3 ~ ø 13 mm)	9002010	20 X 15 X 9 mm (Bolt size: 5mm)	20 X 15 X 8 mm (Bolt size: 5mm)
HBC-613 (ø 3 ~ ø 13 mm)	9002010	20 X 15 X 9 mm (Bolt size: 5mm)	20 X 15 X 8 mm (Bolt size: 5mm)
HBC-316 (ø 3 ~ ø 16 mm)	9002410	22 X 17 X 9 mm (Bolt size: 5mm)	22 X 17 X 9 mm (Bolt size: 5mm)
HBC-16R (ø 3 ~ ø 16 mm)	9002420	22 X 17 X 9 mm (Bolt size: 5mm)	22 X 16.7 X 8 mm (Bolt size: 5mm)
HBC-816 (ø 3 ~ ø 16 mm)	9002020	26 X 20 X 10 mm (Bolt size: 5mm)	21 X 20 X 10 mm (Bolt size: 5mm)
HBC-19R (ø 3 ~ ø 19 mm)	9002030	28 X 20 X 11.5 mm (Bolt size: 5mm)	26 X 20 X 10 mm (Bolt size: 5mm)
HBC-520 (ø 3 ~ ø 20 mm)	9002030	28 X 20 X 11.5 mm (Bolt size: 5mm)	26 X 20 X 10 mm (Bolt size: 5mm)
HBC-22 (ø 3 ~ ø 22 mm)	9002400	30 X 24 X 11 mm (Bolt size: 5mm)	
HBC-225 (ø 4 ~ ø 25 mm)	9002040	36 X 28 X 13 mm (Bolt size: 5mm)	
HBC-232 (ø 4 ~ ø 32 mm)	9002460	44 X 36 X 16 mm (Bolt size: 5mm)	

ADDING OIL

This rebar cutter is electro-hydraulic. When shipped from the factory, it was filled with oil. Do not attempt to add oil as long as the tool performs well. Over a period of time the oil level will gradually go down. Eventually this will cause a noticeable dropping off in performance. When this happens add oil as follows.

1. Place some rebar between the Blades and pull the Trigger Switch.
2. Release the Trigger Switch just before the cut is completed to stop the tool.
3. Unplug the tool so that the Blades cannot be moved accidentally.
4. Remove the Bolt (M10 X 15) which caps the oil filler hole. Add the oil, being careful not to allow any oil to spill into the motor.
5. Replace the Bolt (M10 X 15) and tighten securely.
6. Plug the tool in and complete the cutting operation.
7. Repeat the above procedure several times until the oil level remains correct.

CAUTION

- Only pure hydraulic oil as recommended by Ogura & Company Ltd. should be used in this tool.
- For HBC-25N and HBC-32, use Super Hyrando #32 (Nippon Oil Corporation) or equivalent spec anti-wear Hydraulic Oil, ISO Viscosity Grade 32.
- For all other models use Ogura supplied hydraulic oil, Super Hyrando #46 (Nippon Oil Corporation) or equivalent spec anti-wear Hydraulic Oil, ISO Viscosity Grade 46.
- Do not use other oils as these may cause damage to the seals and other internal machine parts.

TROUBLE SHOOTING

▲ WARNING: Unplug tool from the power source before troubleshooting.

PROBLEM	CAUSE	SOLUTION
Cutter Rod will not extend.	Insufficient oil	Top up oil (Refer to "Adding Oil")
	Cutter Rod has not returned completely due to build up of debris between Cutter Rod and Bar Holder.	Manually push back Cutter Rod. Remove debris and clean.
	Cutter Rod has not returned completely due to damage to the Cutter Rod.	Replace Cutter Rod.
	Cutter Rod has not returned completely due to loose or damaged Cutter Rod Blade.	Tighten Blade bolts. Replace Cutter Rod Blade.
	Cutter Rod has not returned completely due to weak Return Spring.	Replace Return Spring.
Insufficient power to cut rebar.	Insufficient oil	Top up oil (Refer to "Adding Oil")
	Return Valve, not properly seated or seating damaged.	Clean tip of Return Valve and seating. Remove any scratches from seating.
	Return Valve damaged.	Replace.
	Incorrect clearance between Cylinder and Piston.	Replace Piston (Note: different size pistons available)
	Check Valve not properly seated or seating damaged.	Clean Check Valve and seating. Replace.
	Urethane Packing, damaged or broken.	Replace.
Oil leaks.	Oil Leveller Bladder, damaged or broken.	Replace.
	Cutter Rod/Bar Holder, O-Ring damaged; Rod/ Bar Holder surface, grooved.	Replace Back-Up Ring and O-ring. Replace Cutter Rod/Bar Holder
	Cylinder/Bar Holder, O-Ring damaged.	Replace O-ring
	Cylinder/Pump Case, Gasket damaged.	Replace.
	Bar Cutter/Cylinder/Pump Case, flange bolts loose.	Tighten bolts.
Motor not working. Motor slow or erratic.	Voltage incorrect.	Correct.
	Carbon brushes worn.	Replace.
	Armature, damaged or open circuit.	Replace.
	Armature bearings, damaged or broken.	Replace bearings.

NOTE: The internal components of the pump and piston area have very close tolerances and are sensitive to damage from dust, dirt, contamination of the hydraulic fluid or improper handling. The disassembly of the pump housing requires special tools and training, and should only be attempted by qualified repair personnel that have been properly trained and have the right tools. The improper servicing of electrical components can lead to conditions that could cause serious injury. The pump, piston components and all electrical parts should be serviced only by authorized repair shop, dealer or distributor.

Ogura®

2661 Hongo, Ebina City,
Kanagawa-pref., Japan 243-0417
TEL : 046-238-1285 FAX : 046-238-4188

Ogura & Co., Ltd.

IOJIN.8503400/0810